

NO	PART NAME	QTY	MATERIAL	NOTE	PART NO.
08	SET SCREW	2	S435	M3X4	
07	SCREW,CROSS RECESS HEAD w/L PLAIN WASHER	4	SUS304	M4X25	
06	O. RING	1	FKM	S45	1001112311
05	OUTER DRIVE RING	1	ADC-12	φ41X26	
04	IMPELLER VANE	1	PPG	φ33X22.5	1001112303
03-1	SPINDLE	1	CERAMIC	φ4X27	1001212306
03	REAR CASING	1	PPG	φ54X20.5	1001212305
02-1	FRONT THRUST PAD	1	RUION	φ9X1.2	
02	FRONT CASING	1	PPG	HOSE THREAD	1001112310 1011112300
01	MOTOR	1	BRUSH LESS 6 W	DC 12 V DC 24 V	1301212307

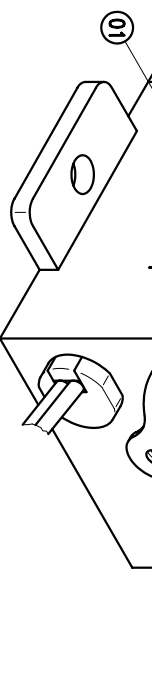

APPROVED	CHECK	MDL NAME	NH-5PX-D
12 31 03	12 31 03	DWG, NAME	DECOMPOSITION DRAWING
02 20 97	02 20 97	DWG, NO.	B3001225
12 31 03 BECKY	12 31 03 BECKY		A3

TPW
HONG YUAN

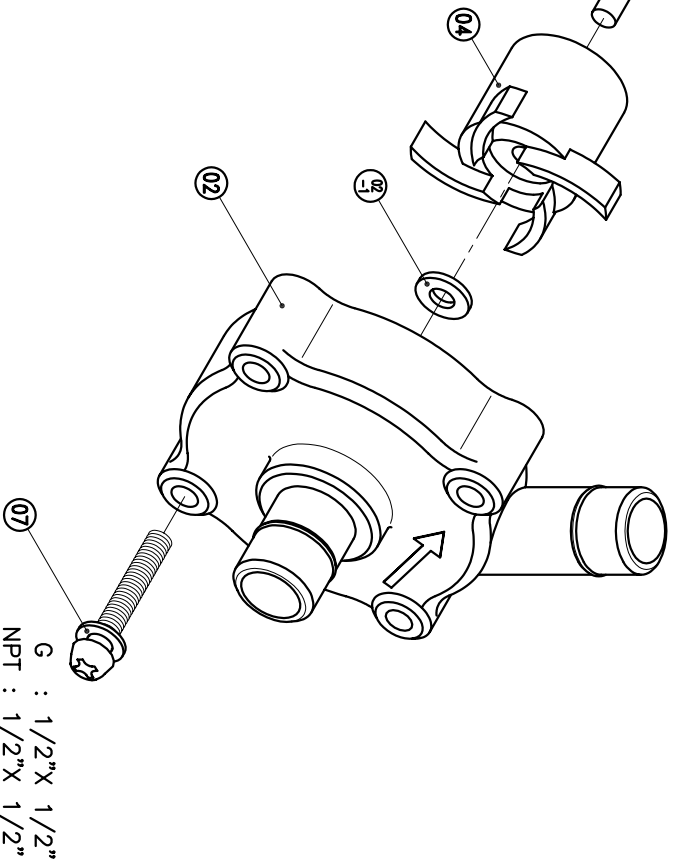
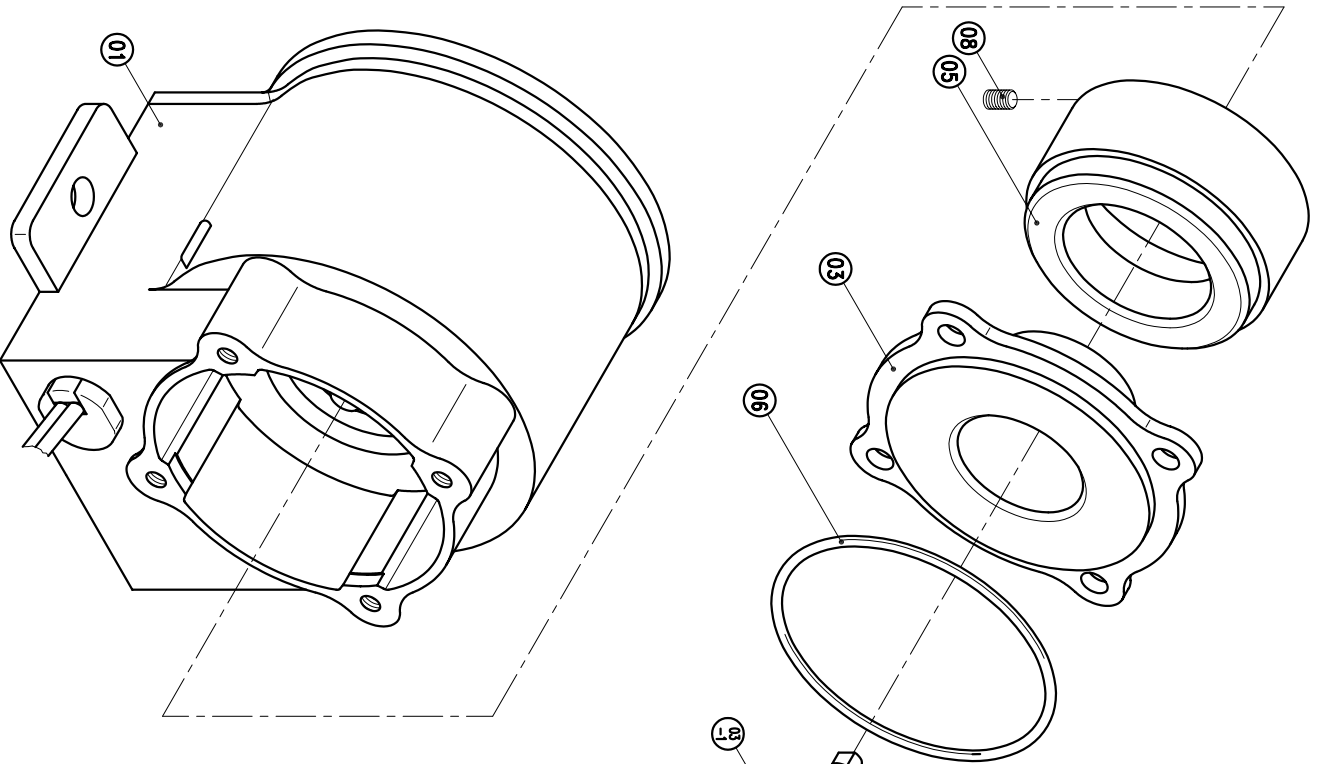

PAN WORLD CO., LTD.
パンワールド株式会社