

NO	PART NAME	Q'TY	MATERIAL	NOTE	PART NO.
08	SET SCREW	2	S435	M3X4	
07	SCREW,CROSS RECESS HEAD w/L PLAIN WASHER	4	SUS304	M4X25	
06	O. RING	1	FKM	S45	1001112311
05	OUTER DRIVE RING	1	ADC-12	φ41X26	
04	IMPELLER VANE	1	PPG	φ40X22.5	1001112304
03-1	SPINDLE	1	CERAMIC	φ4X27	1001212306
03	REAR CASING	1	PPG	φ54X20.5	1001212305
02-1	FRONT THRUST PAD	1	RULON	φ9X1.2	
02	FRONT CASING	1	PPG	HOSE THREAD	1001112310 1011112300
01	MOTOR	1	BRUSH LESS 10 W	DC 12 V DC 24 V	1301212317 1301212318

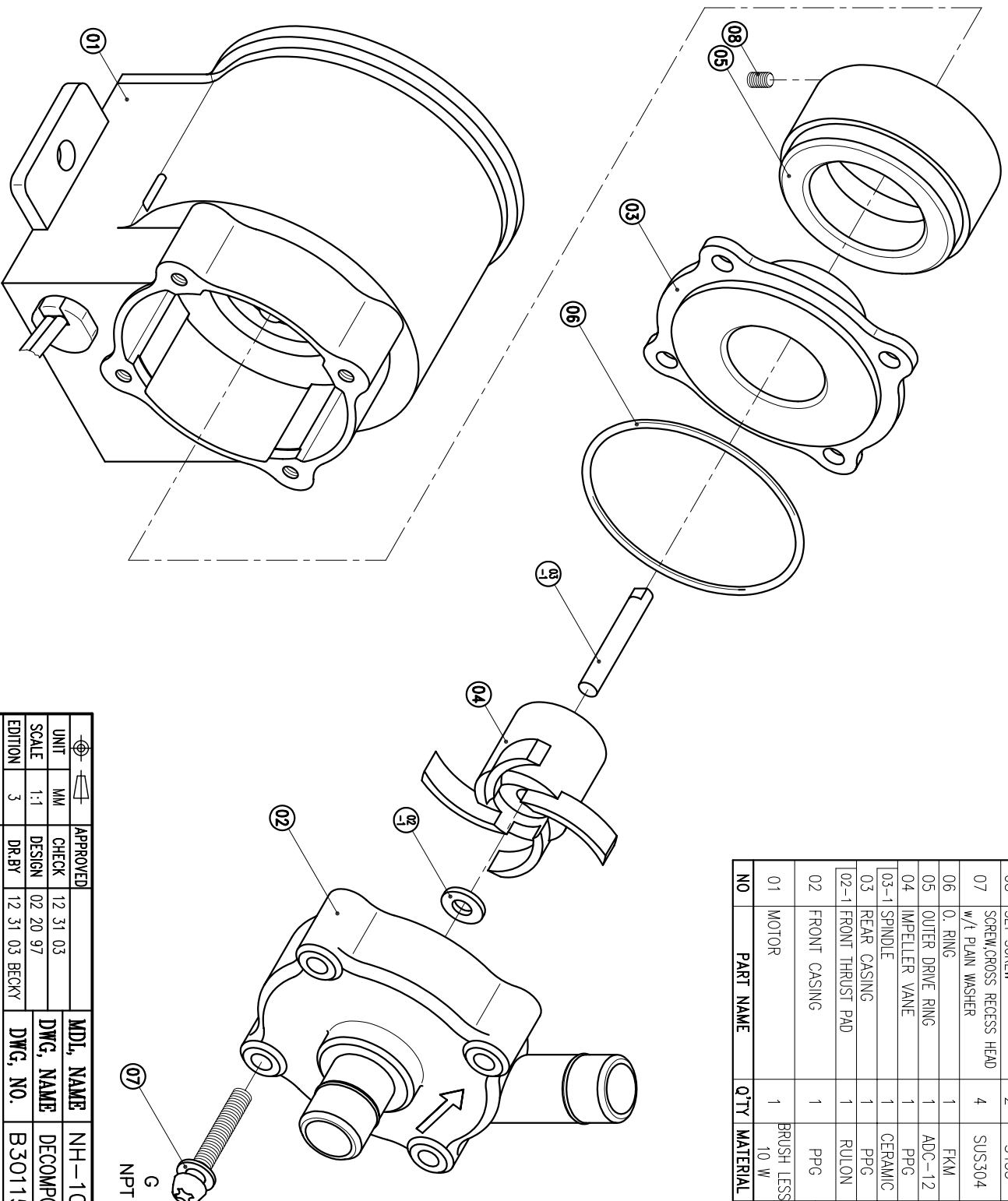

UNIT	MM	CHECK	12 31 03	MDL NAME	NH-10PX-D
SCALE	1:1	DESIGN	02 20 97	DWG. NAME	DECOMPOSITION DRAWING
EDITION	3	DR.BY	12 31 03 BECKY	DWG. NO.	B3011547
					A3

TPW
HONG YUAN



PAN WORLD CO., LTD.
パンワールド株式会社